



**CRUISE SHIP  
NATIONAL CENTER  
OF EXPERTISE**

1800 Eller Dr.  
Suite 420  
Fort Lauderdale, FL  
33316

Phone: 954-767-2140  
Fax: 954-767-8038  
Email: [csncoe@uscg.mil](mailto:csncoe@uscg.mil)

**Inside this issue:**

CVSSA Update	1
Watchful Certification for CCTV Systems	2
Regional Update: Great Lakes Region	3
Shipbuilding in the Age of Innovation	4
Taking Sustainability to the Next Level	6
Fuels Update: LNG in the U.S.	8
Welcome Aboard to our Newest CSNCOE Team Members	9
FY2023 Top Ten Deficiencies Summary	10
Training & Guidance Updates	10

# The Cruise Ship Round Turn

Issue 27

Fall 2023

## CVSSA Regulations Update from the Chief of Operating and Environmental Standards

By Captain Jerry Butwid  
*Chief, Office of Operating and Environmental Standards (CG-OES)*



The Cruise Vessel Security and Safety Act of 2010 (CVSSA) was signed into law on July 27, 2010, to enhance safety and security protections of cruise ship passengers with newly required procedures, equipment, and arrangements. While almost all cruise ships are foreign flagged, these requirements generally apply to all vessels authorized to carry at least 250 passengers. Some key requirements include the installation of higher deck rails to prevent falls overboard, access controls to staterooms, video surveillance, and procedures for deterring and responding to criminal activities onboard. The U.S. Coast Guard determined that many of the requirements were largely self-executing, and published two policy letters in 2011 to provide Port State Control Officers with enforcement guidance. The U.S. Coast Guard published a Notice of Proposed Rulemaking in 2015 with proposed regulations for non-self-

executing requirements listed in 46 U.S. Code Chapter 35.

Since initial implementation, legislators identified needs for the additional protection of cruise ship passengers, and added further requirements to the statute with the passing of the National Defense Authorization Act and Alaskan Tourism Restoration Act in 2021. These additional requirements included more comprehensive arrangements for video surveillance and medical treatment of passengers. While the cruise industry largely complies with many of the new requirements, cruise ship operators have had concerns with provisions for man overboard (MOB) technology and the installation requirements for video surveillance systems.

Section 3507(a) requires the integration of technology for the image capture or detection of passengers who have fallen overboard. In July 2016, the U.S. Coast Guard published a Notice of Request for comments on the status of overboard technology for cruise vessels, and has thoroughly reviewed the five submissions from vendors, cruise lines, and cruise passenger advocacy groups. The U.S. Coast Guard has been tracking the development of MOB technology, and completed its work with the International Organization for Standardization (ISO) to develop ISO Standard 21195 for MOB technology. This standard is published to provide the

cruise industry with best practices and clear guidance for MOB technology.

Section 3507(b) requires cruise vessel owners to install and maintain a video surveillance system by completing a risk assessment, surveillance plan, and installation plan with attestation documenting the video surveillance equipment is installed in accordance with the surveillance plan. While generally all cruise vessels have video surveillance systems, cruise industry stakeholders have been working through technical variables such as record retention, video quality, frame speed, and camera locations.

Despite these challenges, the cruise industry has collaborated with Recognized Organizations and the U.S. Coast Guard to comply with the CVSSA requirements and plan for the installation of new technologies as they develop. Last year, the U.S. Coast Guard decided to move forward with a Supplemental Notice of Proposed Rulemaking (SNPRM) to incorporate CVSSA's legislative updates. Information on the SNPRM can be found in the long-term actions section of the Spring 2023 Unified Agenda under Regulation Identifier Number, [RIN 1625-AB91](#). The U.S. Coast Guard's Unified Agenda is updated in the Fall and Spring of each year. Industry stakeholders may find all future announcements regarding this rulemaking published in the Federal Register.

## WATCHFUL Certification: A method to validate the evolution of CCTV systems onboard cruise ships

by Luca Carrà

RINA USA Inc., U.S. Passenger Excellence Center

The maritime industry constantly evolves to ensure safer and more efficient operations. While safety and security remain paramount for ship Owners and Port Operators in this digital age, the integration of advanced technologies is imperative.

During the early to mid-20th century, Closed Circuit Television (CCTV) systems started with the basic setup of analog arrangements with limited coverage and low-resolution images. The transition to digital arrangements that took place from the late 20th century to the early 2000s made available digital cameras that could offer higher resolution and better image quality, digital recording, and remote monitoring, enabling real-time surveillance.

The latest generation of computer-based systems introduced the adoption of IP-based CCTV systems composed of hardware and software, with network cameras, and high-definition (HD) camera resolutions that provide clear and detailed images, essential for security and safety purposes, utilizing existing ship network infrastructure. New features such as video analytics, motion detection, dual sensors technology, self-backup data process, automatic reporting, and alert systems, enhance the system's effectiveness in identifying and responding to security threats becoming smarter and more interconnected with other technologies and third-party systems, such as access control and alarm systems, creating a comprehensive security network.

The introduction of alternative designs in the latest generation of cruise ships, allows CCTV systems on ships to not only enhance security but also aid in monitoring operations, ensuring crew and ship safety.

RINA, as an IACS member and a global provider of classification, certification, testing, and inspection services, designed a tailored qualification method for the CCTV System called WATCHFUL.

This holistic approach validates novel technology and solutions adopted during the design phase of CCTV Systems to verify, among other requirements, its fitness for purpose, its safety and reliability, and its compliance with the applicable regulatory framework, specifically designed for Cruise Ship Operators. A significant added value of the Watchful Certification is the optimization of the camera's coverage process in terms of numbers, models, and locations, where the Flow Path Monitoring approach evaluates the area to

be monitored, considering its surroundings and access routes.

This optimization process can start from the review of the ship's CAD layout plans, supporting operators, owners, and ship designers with an immediate graphical understanding of the following:

- AS IS layout to show the ship's decks CCTV coverage, highlighting the possible blind areas, and
- AS TO BE layout to present the modified areas and CCTV positioning in order to reduce the blind sectors previously identified considering camera models, data sheets and performances.

The optimization of the camera's coverage process, is applicable both on board and

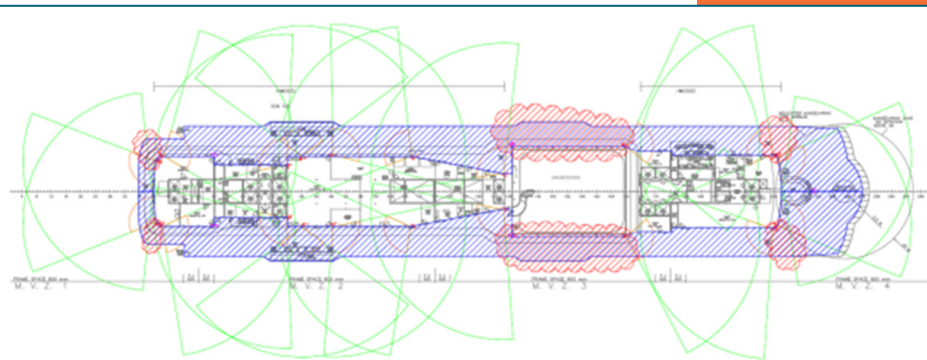

External area AS IS coverage drawing example

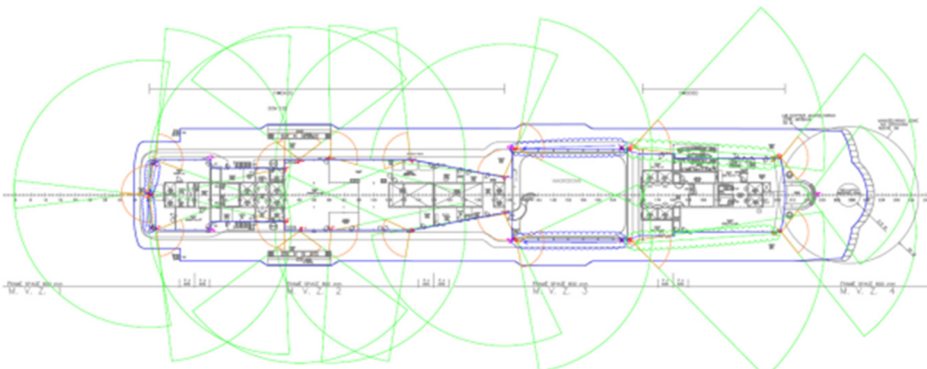

External area AS TO BE coverage drawing example

ashore (Port and Owners Terminals), providing a more homogeneous security interface. The optimization process is aimed at reducing the number of CCTV cameras, optimizing the system layout together with network configuration, supporting designers/shipyards/owners in the installation process, and security operators in its operability and maintenance procedures. Part of the process is an accurate analysis of the CCTV system, which typically includes fundamental considerations, such as ship type, surveillance location, type of technology, coverage area optimization, and network integration.

The WATCHFUL Certification process has the main goals to 1) Confirm and validate that the proposed technology used by the CCTV System, meets specified requirements for its intended service, with respect to the applicable classification

requirements of the ship, and is in compliance with specific applicable rules/guidelines/standards, and 2) Certify that the design and operation of the CCTV and Security System installed on board the vessels fit the "Security and Operational Requirements of the Company" fully harmonized with Class, IACS, and environmental requirements.

By addressing key aspects such as system security, reliability, and compliance with industry standards, RINA WATCHFUL Certification provides ship operators and stakeholders with the confidence that the computer-based systems meet the stringent requirements necessary for maritime use, adopting novel solutions and features aligned with new needs of the maritime sector.

In conclusion, the RINA WATCHFUL Certification

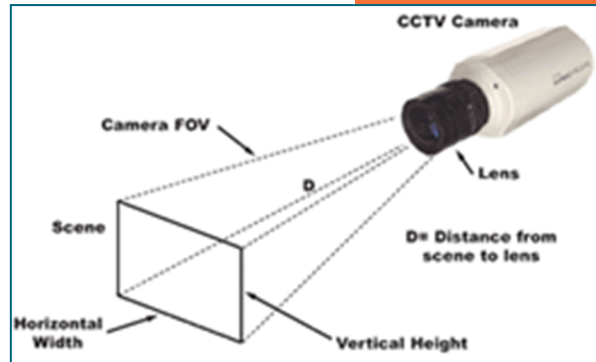

Sample Camera with Coverage Factors Shown

stands as a comprehensive and robust standard that effectively encompasses all the essential criteria for the acceptance of a modern CCTV system on board ships.

This certification not only ensures the seamless integration of advanced technological solutions but also guarantees the highest levels of safety, efficiency, and reliability in maritime operations.

## Cruise Industry Growth in the Great Lakes Region

by Ms. Rebecca Yackley

Director, Office of Trade & Economic Development, Great Lakes St. Lawrence Seaway Development Corp.

The 2023 Great Lakes cruising season has been the busiest yet. Seven cruise lines designed itineraries for ten vessels on the Great Lakes this year, totaling almost 400 U.S. port calls and a high estimate of 100,000 passengers by the end of the cruise season. This uptick in activity meant the expansion of the number of locations where vessels called for the 2023 season. A total of 17 U.S. ports were selected, with more under development for future seasons. Excitement over seeing cruise ships on the Great Lakes continued to garner positive attention from the media. Not surprising to those of us who know the area, the Great Lakes destinations continue to be highlighted as must-see in travel magazines such as Conde Nast and National Geographic. Great Lakes cruise destinations have extolled the impact on

tourism in their communities.

As a burgeoning industry, it is difficult to quantify the exact economic impact that cruising is having on the Great Lakes overall, but ports are widely reporting that cruising is injecting a

welcome boost of tourism dollars into their small communities. This holds especially true for ports who host turnaround calls, where one set of passengers ends their cruise, and another set embarks on a new



Le Bellot Docked in Milwaukee, WI



adventure. Duluth, MN and Milwaukee, WI, both of whom host turnaround calls, report that the hotel stays, restaurant dollars, and tourism attractions visited in pre- and post-cruise packages are significant to their economy.

One particular location is considered a linchpin to Great Lakes cruising: Mackinac Island, MI. With world-famous Mackinac Island fudge and car-free streets full of horse-drawn carriages, it is a unique destination known as a jewel central to the Great Lakes. All six cruise lines that visit the U.S. side of the Great Lakes in 2023 built Mackinac Island into their itinerary offerings.

Ports of call that have established U.S. Customs and Border Protection clearing facilities have seen increased cruise traffic. These ports include Cleveland, OH, and Duluth, MN. Other U.S. ports of entry for clearing are Detroit and Sault Ste. Marie, MI. Since the Great Lakes St. Lawrence Seaway lies between two countries, passengers must receive clearance each time they enter the U.S. after visiting a Canadian port. These four cities recognize the criticality of providing an easy, seamless experience for passengers on vacation.

With this increased attention on cruising in the Great Lakes, many port communities are

looking at the potential of adding cruise ship visits to their port communities as well. In 2023, Escanaba, MI, Fayette, MI, and Buffalo, NY had the opportunity to host their first cruise vessels. Additional locations are being discussed for 2024 itineraries and beyond.

While the demand for Great Lakes cruise tourism remains strong, the 2024 season will see a slight decrease in port calls due to the sale of the American Queen Voyages vessels, *Ocean Navigator* and *Ocean Voyager*. While these vessels, built in the early 2000s, are retiring, American Queen Voyages remains a supporter of the Great Lakes region. Although the loss of these vessels may be discouraging, it should be noted that the newest Seaway-size cruise vessels are not only more modern and offer a heightened passenger experience, but also add passenger

capacity on a per vessel basis. As a result, the passenger count and community impact should remain high.

Overall, the Great Lakes is excellently positioned to continue providing outstanding cruise experiences to passengers. The Great Lakes St. Lawrence Seaway Development Corporation (GLS), in partnership with the Great Lakes Cruising Coalition (GLCC), Great Lakes Cruise Association (GLCA), Cruise the Great Lakes (CTGL), and Cruise the St. Lawrence (CTSL), will continue raising awareness of the region as a cruise destination with a unique and fresh experience for passengers. Itineraries that incorporate all five Great Lakes, 17 U.S. ports, and 18 Canadian ports are being sold worldwide, raising the profile of the Great Lakes and its destinations in a global cruising market.

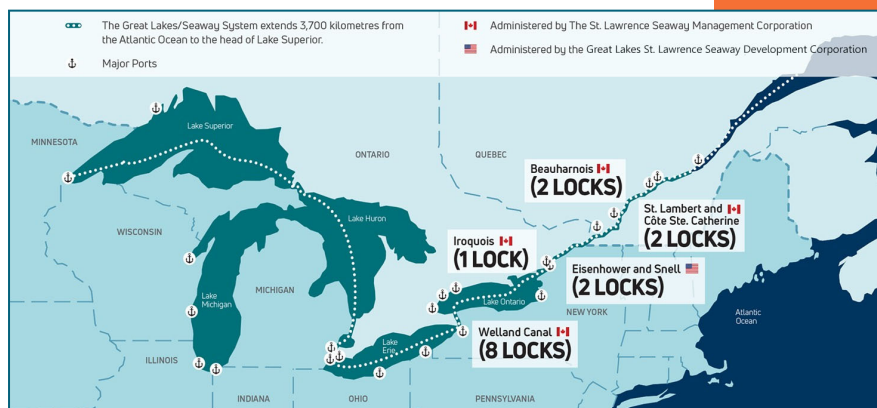

## Shipbuilding in the Age of Innovation: A journey from pandemic to zero emissions

by Mr. Marco Bognolo  
Vice President, Basic Design, Fincantieri S.p.A.

During the COVID-19 pandemic, many people may have argued how the cruise sector would recover. Recent statistics demonstrate the resilience of the industry as key performance indicators such as the number of passengers, revenue, or bookings, show a steady

upward trend compared to the pandemic lows.

Such experience brought also remarkable improvements in vessels design and operation, such as comprehensive health and safety measures implemented to mitigate the risk of infection on cruise ships, like

## FINCANTIERI

enhanced cleaning procedures, testing protocols, and contactless services.

Overall, the execution of newbuild orders in the cruise industry is a positive indicator of recovery and growth. It reflects confidence in the industry's prospects and its com-

*“Passengers may have to play their role in sustainability too, since the adoption of responsible travel practices and encouraging eco-friendly behaviors, such as minimizing energy consumption during their time on board, can contribute to emissions reduction efforts.”*

mitment to delivering exceptional cruise experiences to passengers.

Newbuild orders also indicate a clear commitment to innovation as new ships often come with innovative features and amenities to provide passengers with exciting and modern cruise experiences. Additionally, modern vessels often offer improved energy efficiency, sustainability features, and passenger comfort, which can attract more customers, thus helping cruise companies to maintain a competitive edge in the industry.

Fincantieri, as leading shipbuilding company in the cruise ship industry, has focused the industrial plan of the next years to consolidate its position, placing a strong emphasis on quality, innovation, sustainability and digitalization. New designs incorporate cutting-edge technology and innovation, such as advanced propulsion plants, energy-efficient systems to reduce emissions, and state-of-the-art onboard amenities. Flexibility is also a key factor, for the company works closely with cruise operators to customize ship designs according to their specific requirements and branding, allowing cruise companies to create unique and distinctive cruise experiences.

While continuing the projects at its multiple yards, Fincantieri must face several challenges. These include, for instance, disruptions in the supply chain, which can impact project timelines and costs, labor shortage, requests of incorporating advanced technologies and systems ensuring they work seamlessly together, as well as the requirements to meet stringent regulations in terms of safety, environmental, and operational standards, which may pose challenges in design and construction.

Staying at the forefront of shipbuilding technology and

innovation while meeting the evolving expectations of cruise lines and their passengers for more advanced, sustainable, and luxurious ships requires ongoing research and development efforts. In particular, the demanding requirements set for decarbonization by European and international rules had a significant influence on technological innovation in the cruise sector.

New cruise ship prototypes will prioritize energy efficiency and emissions reduction from the design phase. To meet decarbonization targets, Fincantieri invested in alternative fuels and innovative technologies, such as LNG (liquefied natural gas) and methanol engines, hydrogen fuel cells and batteries, which can reduce greenhouse gas emissions compared to traditional diesel engines.

Energy efficiency enhancements are also important to reduce fuel consumption, and therefore emissions, and new prototype cruise designs are strongly characterized by energy-saving measures and technologies, such as hull forms based on advanced CFD optimization, reduced frictional resistance based on air lubrication and innovative paints, as well as more efficient systems onboard combined with advanced monitoring and data analytics systems to optimize fuel efficiency and route planning. The adoption of advanced

energy management systems and predictive analytics will allow cruise ships to optimize energy use, reducing emissions by minimizing unnecessary power generation.

State-of-the-art waste heat recovery systems can capture and reuse heat generated by the engines and onboard systems, improving overall energy efficiency. Similarly, cold recovery systems are used to exploit the energetic content along the transformation of natural gas from its liquid state. Some futuristic project may consider incorporating renewable energy sources, such as solar panels and wind turbines and sails, to supplement onboard power generation and decrease reliance on fossil fuels. Ship design may also benefit from the use of innovations in sustainable materials that can contribute to lighter vessels, reducing energy consumption and emissions.

The efforts for reduction of the environmental footprint do not involve only air emissions. Innovation also embraces the waste management systems, with new vessels equipped with advanced recycling and waste-to-energy technologies to minimize their emissions into the water. And underwater noise is becoming a key design parameter too, determining new propulsion systems being specifically optimized to achieve the requested speed performances while



**Cruise Ship Silver Dawn, delivered in November 2021 from Fincantieri's Ancona, Italy Shipyard**



**Cruise Ship Norwegian Prima, delivered in July 2022 from Fincantieri's Marghera, Italy Shipyard**

reducing the underwater noise.

The outstanding care for the environment undertaken by Fincantieri new designs is also certified by specific class notations, setting more stringent levels for emissions to the air and discharges to the sea than what either the International Maritime Organization or most flag states require, and ensuring that ships do not exceed established underwater radiation noise levels, minimizing their impact on marine life.

When considering the cruise market, remarkable changes will also impact the infrastructures and, to some extent, the whole cruise experience. The development of hybrid and all-electric cruise ships may accelerate, especially for shorter coastal routes. Advances in battery technology and charging infrastructure will be essential for these innovations, for modern ports equipped with shore power infrastructure will allow cruise ships to connect

to the local power grid while in port, reducing the need to run onboard engines during docking.

In the interim deployment of shore power facilities across various destinations, cruise vessels are designed to rely on a combination of strategies and technologies to reduce emissions and minimize their environmental impact, which include shutting down non-essential systems and the use of alternative power sources while in port, such as fuel cells or battery energy storage systems.

To reduce emissions and comply with new regulations, cruise ships may also require important operational adaptations. Opting for reduced speeds and shorter itineraries will require less time at sea, focusing on regional or coastal cruises rather than long transoceanic voyages. Interactive advanced navigation and routing technologies will be applied to identify the most fuel-efficient routes, considering

weather conditions and currents.

Passengers may have to play their role in sustainability too, since the adoption of responsible travel practices and encouraging eco-friendly behaviors, such as minimizing energy consumption during their time on board, can contribute to emissions reduction efforts.

Changes in passenger approach to cruising are also testified by the increased interest in small and medium-sized vessels in the current cruise market. This can be attributed to several factors that cater to changing passenger preferences and industry dynamics. Small and medium-sized ships typically offer a more intimate and personalized cruise experience; they can access smaller and less-visited ports and harbors that are off-limits to larger vessels, revealing opportunities for passengers to explore less crowded and more culturally rich destinations, aligning with evolving passenger preferences for sustainability and wellness-focused travel.

In summary, while facing repeated challenges along its evolutionary process, the cruise sector proves its resilience with continuous changes and innovations capable of responding to the increasingly demanding decarbonization requirements and, at the same time, improving passenger experience on board as well as targeting a more sustainable and environmentally responsible cruise industry in the future.

## Taking Sustainability to the Next Level: EGR treatment systems

by Mr. Martin Gombrii  
Managing Director, Marinfloc Sales and Production AB

Cruise ships have come a long way in adopting environmentally friendly practices to reduce their impact on the oceans and the atmosphere. One of the significant challenges in this regard is meeting Tier

III emission requirements. Exhaust Gas Recirculation (EGR) systems have been proposed as a viable solution for cruise ships to fulfill these stringent standards. It is important to understand how EGR systems

can play a vital role in achieving Tier III compliance and how a combined treatment unit for bilge and EGR bleed-off water can contribute to protecting the environment and the crew.

Tier III emission standards,

**MARINFLOC**  
SALES & PRODUCTION





set by the International Maritime Organization (IMO), are aimed at reducing the emissions of nitrogen oxides (NOx) from marine engines, which are a major contributor to air pollution and acid rain. Cruise ships are under increasing pressure to meet these standards, particularly in sensitive coastal areas.

EGR is a technology that has gained prominence in the shipping industry as a means of achieving Tier III compliance. It works by recirculating a portion of the exhaust gases back into the engine's combustion chamber, reducing the formation of NOx emissions. This process significantly lowers the environmental impact of cruise ship engines without compromising on performance.

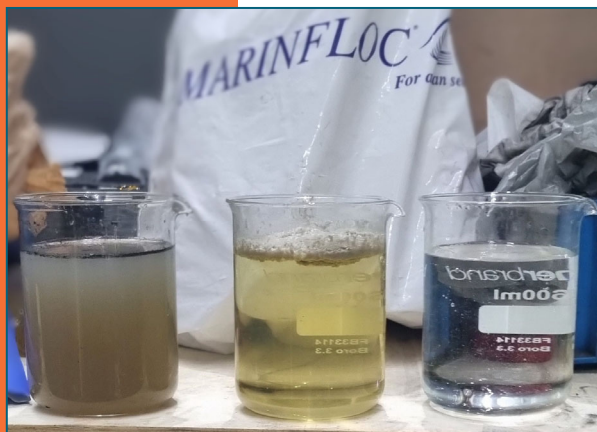

Sample beakers showing untreated influent, flocculated effluent, and filtered effluent

#### Bleed-off Water Challenge.

While EGR technology is effective in reducing NOx emissions, it introduces a new challenge: the management of bleed-off water. EGR systems use a water scrubber to cool and clean the recirculated exhaust gases. This scrubber produces a wastewater stream that is similar in composition to bilge water, containing contaminants such as emulsified oil, heavy metals, and other pollutants.

Managing this bleed-off water is essential, as discharging it into the ocean untreated poses

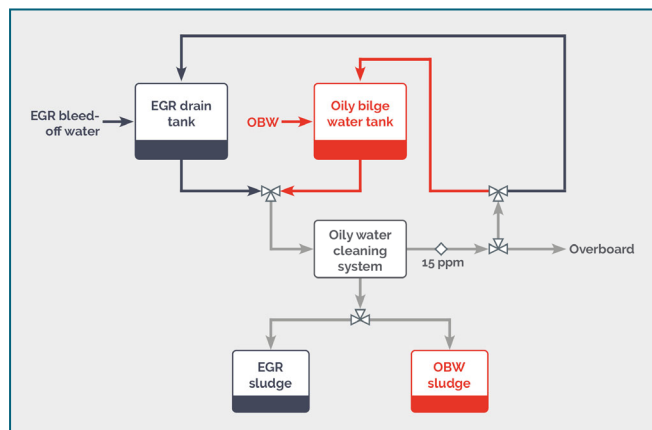

#### Combined EGR & Bilge Water Treatment System

serious environmental and legal concerns. To address the challenge of managing both EGR bleed-off water and bilge water, a combined treatment unit offers an innovative and sustainable solution. This unit integrates advanced technologies for treating both wastewater streams simultaneously, ensuring compliance with environmental regulations and reducing the environmental footprint. The key benefits of a combined treatment unit include: 1) Environmental Protection: A combined treatment unit efficiently removes contaminants from both EGR bleed-off water and bilge water, ensuring that neither stream poses a threat to marine ecosystems. This technology aligns with the cruise industry's commitment to responsible environmental practices; 2) Crew Safety: A combined treatment unit eliminates the need for separate treatment systems, simplifying operations and reducing potential exposure to hazardous substances; 3) Regulatory Compliance: By effectively treating both wastewater streams, cruise ships can meet MARPOL and other regulatory requirements. This not only avoids costly fines but also upholds the industry's reputation as a responsible environmental steward; and 4) Resource Efficiency: Combining the treatment of EGR bleed-off water and bilge water leads to

resource and energy savings. This promotes sustainability and reduces operational costs for cruise operators.

#### The Role of Whitebox Technology

A crucial component of any combined treatment unit is the implementation of a "Whitebox." This refers to a system that continually monitors and optimizes the treatment process. The Whitebox technology ensures that the treatment unit operates at maximum efficiency, minimizes chemical usage, and reduces maintenance requirements.

The Whitebox was developed to ensure compliant discharge of bilge water overboard and is installed on the majority of cruise ships. The Whitebox contains equipment required to control and monitor the overboard discharge such as an oil content meter, flow switch, flow meter, and three-way valve. The equipment is locked in a cabinet and all signals including door position is logged in a recorder including vessels GPS position and time so all discharge data is available and can be presented to a PSC officer.

As EGR bleed off water provides the same type of regulatory and technical challenges as bilge water it is required for the combined treatment solution to manage discharge documentation for the two waste streams for the Oil

record book and EGR record book.

As cruise ships strive to meet Tier III emission requirements and maintain their commitment to environmental sustainability, EGR systems have emerged as a viable solution. However, the management of EGR bleed-off water, which resembles bilge water, presents new challenges.

A combined treatment unit that efficiently processes both types of wastewaters not only helps cruise ships meet regulatory compliance but also underscores their dedication to protecting the environment and the well-being of their crew. The implementation of

the Whitebox technology, also on this waste stream further enhances compliant operations

of what otherwise might be a future source of marine pollution.



Typical Whitebox technology arrangement

## Fuels Update: LNG availability in the United States

by Lieutenant Commander J.J. League

National Technical Advisor, Liquefied Natural Gas National Center of Expertise

Liquefied Natural Gas (LNG) bunkering is gaining popularity in US ports due to its ability to reduce emissions, lower bunkering costs, and the increasing availability. LNG demonstrates a cleaner environmental footprint compared to traditional marine fuels, making it a compelling choice due to more stringent emission regulations. LNG offers an immediately

viable and cost-effective alternative compared to oil-based fuels. DNV states that LNG greenhouse gases can be reduced by up to 23% with modern engine technology, reduces NOx by up to 80%, and almost eliminates SOx. Despite its lower energy density, LNG remains competitively priced and reasonably available, increasing its adoption as fuel.

While LNG use as a marine fuel dates back to the 1960s, it only recently gained acceptance in the US around 2012, when TOTE constructed two Jones Act LNG containerships and Harvey Gulf constructed five LNG powered offshore supply vessels. Today there are 19 US-flagged Jones Act LNG-powered vessels and over 400 foreign-flagged LNG-powered vessels, excluding the fleet of over 600 LNG-powered carriers, with more vessels on order books in the US and worldwide.

Presently, the LNG infrastructure caters to most ves-

sel bunkering needs through a combination of transfer methods, including truck-to-vessel, vessel-to-vessel, and facility-to-vessel transfers. Trucks, due to their high mobility and low investment requirements, are frequently utilized for bunkering smaller vessels or in ports that do not regularly bunker LNG powered vessels. However, they necessitate multiple trucks which may also impact wharf access and have a limited capacity (40-80 m<sup>3</sup>) and relatively low flow rate (1,000 liters/min).

In contrast, shore infrastructure and barges provide a more substantial LNG capacity and flow rate than trucks but come at a higher capital cost. Notable LNG bunkering facilities exist in Jacksonville, FL; Port Fourchon, LA; Tacoma, WA; and LNG barges in Cavanaugh, FL. Harvey Gulf's 1000 m<sup>3</sup> facility in Port Fourchon, LA was the first LNG bunkering facility in the US when it started operation in 2015 and currently has completed more

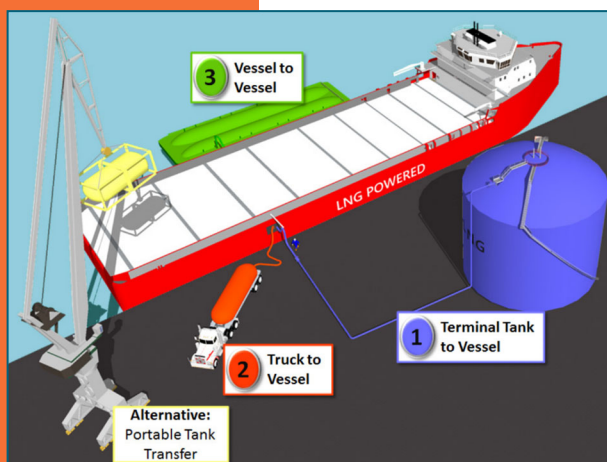

Bunkering Options Available at U.S. Terminals

Graphic Courtesy of ABS



than 1000 transfers. Puget LNG in Tacoma, WA, inaugurated the second LNG bunkering facility in the US in 2022, boasting a capacity of 30,000 m<sup>3</sup> and a flow rate of 600 m<sup>3</sup>/hr. Jacksonville's Talleyrand marine LNG terminal, with a 1,000 m<sup>3</sup> capacity and a design flow rate of 10,000 liters/min can bunker a container vessel in 8 hours. Ports like Canaveral, FL, and Jacksonville, FL, feature LNG bunker barges with capacities ranging from 2,200 to 5,000 m<sup>3</sup>, allowing vessels to meet emission requirements while

supporting the bunkering needs of the container and cruise ships.

However, LNG barges and shore facilities are considerably more expensive than traditional bunkering facilities. For instance, a diesel barge can be procured for \$2-5 million, while an LNG barge investment, ranges between \$50-100 million or more. Likewise, shore terminals, such as the Puget LNG terminal, cost \$310 million. Despite these high costs, the industry continues to invest in LNG, with plans for

shoreside facilities in Galveston and Corpus Christi, alongside contracts for additional LNG bunker barges.

LNG bunkering stands as a promising solution, transitioning the maritime industry towards a more sustainable and eco-friendly future. With ongoing advancements and increasing accessibility, LNG is poised to play a pivotal role in reducing the shipping industry's environmental impact and aligning with emission requirements for the largest and newest ships.



## Welcome Aboard to our Newest CSNCOE Team Members



**LCDR John Di Nino** assumed the role of National Technical Advisor at the CSNCOE in July 2023. John comes to the team with a wealth of cruise ship compliance experience. Previously, he served as Commanding Officer of Marine Safety Unit Port Canaveral where he oversaw all marine safety, security, and environmental protection mission responsibilities.

John also served as the Major Vessel Branch Chief at the Marine Safety Center in Washington, D.C., where he oversaw plan review for foreign passenger vessels entering the Initial Certificate of Compliance program, in addition to plan approval for all deep draft cargo and passenger vessels in the U.S. fleet.

Prior to earning Master's Degrees in Naval Architecture & Marine Engineering, and In-

dustrial & Operations Engineering at the University of Michigan, John served as Chief of the Domestic Vessels Branch at Sector Virginia, and as an engineering officer on the Coast Guard Cutter TAHOMA. John is also a graduate of the U.S. Coast Guard Academy and the U.S. Naval War College.

As National Technical Advisor, John is responsible for align global compliance efforts with fellow Port State and Flag State authorities, and Recognized Organizations. He also advises the Commandant on regulatory and policy matters regarding cruise ship compliance, which is especially important in this age of shipboard innovation.



**LCDR(s) Richard Quintana** joined the CSNCOE team in August 2023 as the National

Port State Control Specialist. Richard comes to the team also with vast experience in cruise ship compliance. Most recently, he served as the Supervisor of the Marine Safety Detachment in American Samoa, overseeing all maritime compliance matters in this unique region. Richard is also one of the Coast Guard's experts for Liquefied Natural Gas (LNG) training and inspection efforts.

Richard also served as a Marine Inspector and Investigator as Marine Safety Detachment Port Canaveral and Sector Mobile. His cruise industry knowledge is well founded on a series of internships through the Coast Guard's Merchant Marine Industry Training Program, with industry stakeholders including Lloyd's Register, Disney Cruise Line, and Q-LNG Transport, LLC.

Richard has nearly 20 years of shipboard and shoreside experience in the U.S. Coast Guard, and holds an MBA from the University of North-central University.

As National Port State Control Specialist, Richard is responsible for coordinating with all Tier 1, 2, & 3 units in executing the nation's COC compliance program.



**Contact the CSNCOE:**

Email:  
[csncoe@uscg.mil](mailto:csncoe@uscg.mil)

Website:  
[www.dco.uscg.mil/CSNCOE/](http://www.dco.uscg.mil/CSNCOE/)

LinkedIn:  
[LinkedIn.com/company/Coast-Guard-National-Center-of-Expertise](https://www.linkedin.com/company/Coast-Guard-National-Center-of-Expertise)

YouTube:  
[@uscoastguardcruiseshipncoe4026](https://www.youtube.com/@uscoastguardcruiseshipncoe4026)

Detachment Chief:  
 CDR Jason Kling

Global Technical Advisor:  
 LCDR John Di Nino

National Mission & Training  
 Coordinator:  
 LCDR Nate Herring

National Port State Control  
 Specialist:  
 LCDR(s) Richard Quintana

**Senior Marine Inspectors:**

- Mr. Daniel Brehm
- Mr. Scott Elphison
- Mr. James Garzon
- Mr. Eric Jesionowski
- Mr. Brad Schoenwald



## Top Ten Deficiencies in Fiscal Year 2023

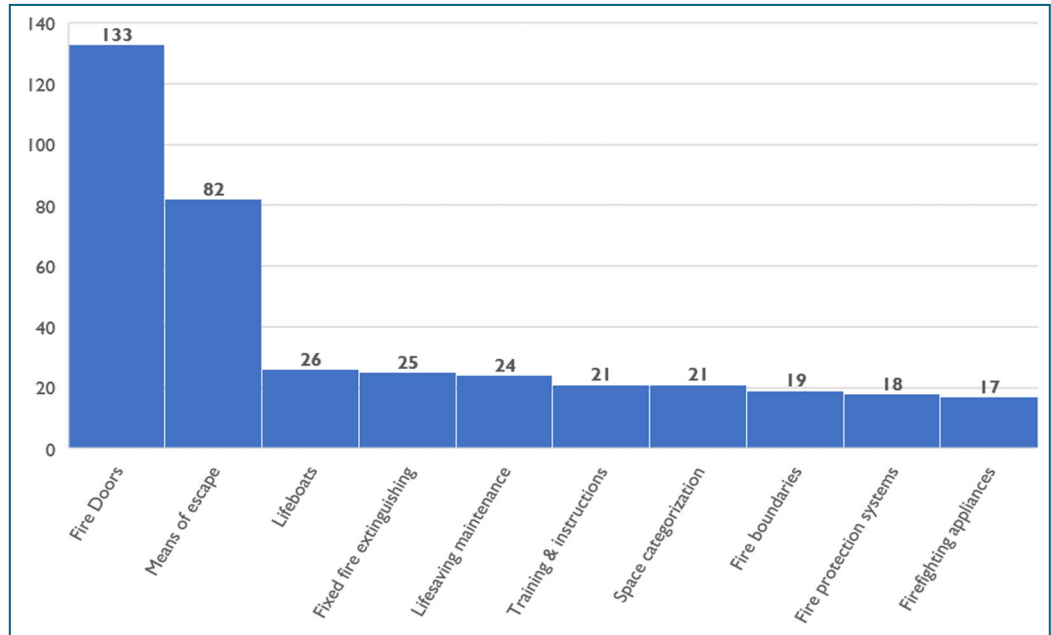

### Training Updates

**FPVE Underway Course**

There will be 3 course convenings next year in the months of February, April, and November. Interested PSCOs must submit an ETR in order to be considered for enrollment. We highly recommend ship managers, class society surveyors, and Flag inspectors to also attend with our USCG students. If interested, please send us an email for further details.

**FPVE Roundtable**

On a quarterly basis, the CSNCOE hosts a roundtable meeting among all FPVEs throughout the Coast Guard. We'll send Teams meeting invites to all FPVEs and trainees ahead of time so you may plan to attend. If you would like a specific topic to be covered, please send us an email.

**Cruise Ship Round Turn Podcast**

Our team recently started a podcast to provide just-in time training information on exam

procedures. You may access the podcast episodes on our YouTube page. Episode topic requests can be sent to us by email.

**Recommended Practices**

The CSNCOE has started publishing Recommended Practices (RP) to guide FPVEs in handling challenging compliance scenarios during COC exams. The RPs are intended to improve consistency among Coast Guard units in issuing port state control actions. The following RPs have been published:

- RP-01:** Best practice for Documenting Storage of Combustibles in Prohibited Spaces
- RP-02:** Best Practice for Documenting Crew Proficiency Deficiencies
- RP-03:** Best Practice for Witnessing Abandon Ship Drills on Cruise Ships
- RP-04:** Best Practice for Documenting Escape Route Deficiencies

### Guidance Updates

The Tactics, Techniques, and Procedures (TTP) for Annual COC exams has been replaced by the CSNCOE Work Instruction **Guide for Conducting Annual Certificate of Compliance Examinations**. In tandem, the **FPV Annual Exam Process Guide** has been updated to incorporate new exam procedures.

The Guide for Conducting Periodic Certificate of Compliance Examinations is expected to be published by the end of this calendar year. The **FPV Periodic Exam Process Guide** has been updated to align drill procedures with the Annual Process Guide.

Revision 3 of the Guide for Conducting **USCG Initial COC Examinations of Foreign Passenger Vessels** has been published.

*These documents are available on our webpage and the internal CGPortal Online page.*